

Assembling instruction

900 / 1200 / 1400 mm

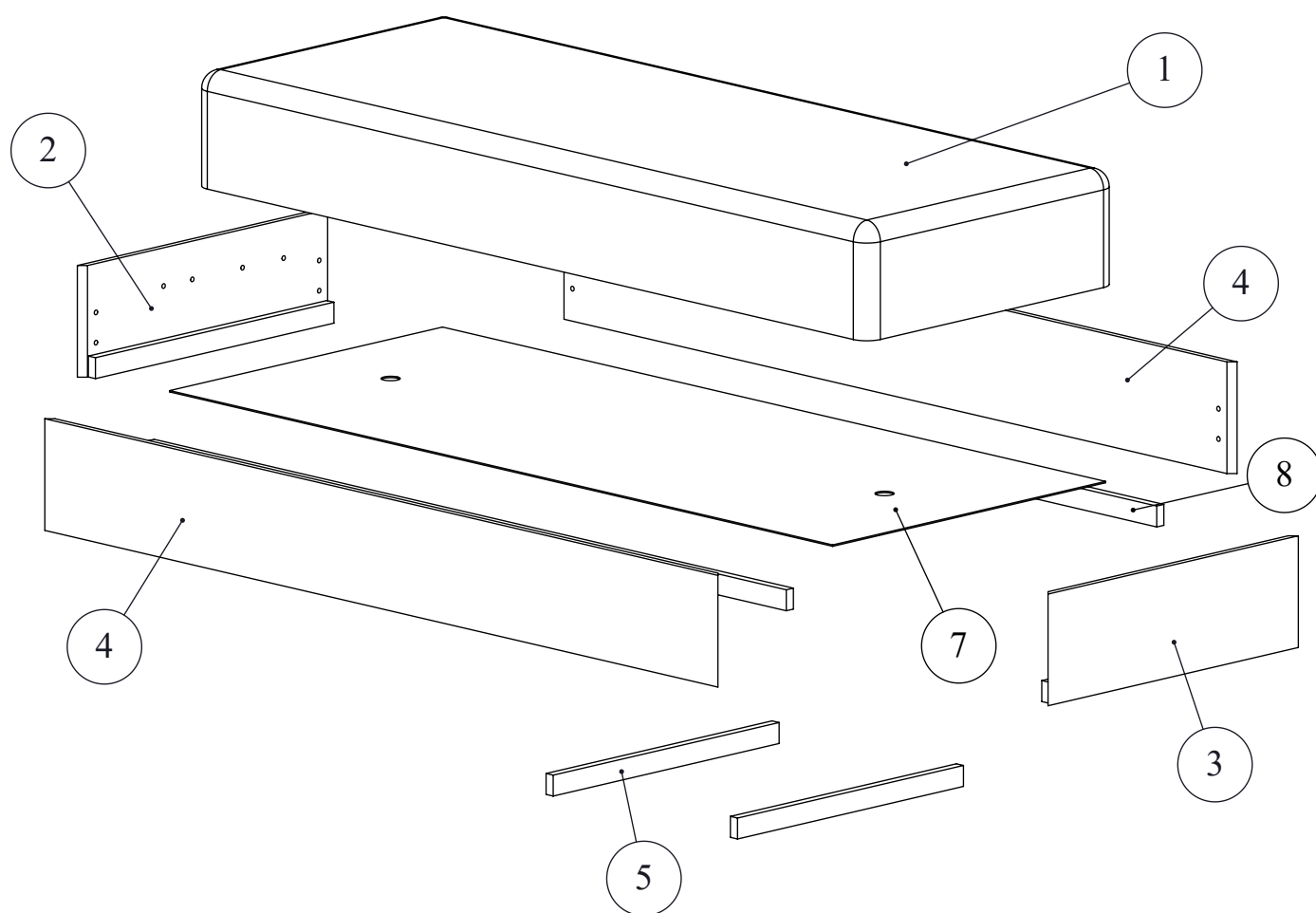

①	x1	⑦	x1
②	x1	⑧	x2
③	x1		
④	x2		
⑤	x2		

1600 / 1800 mm

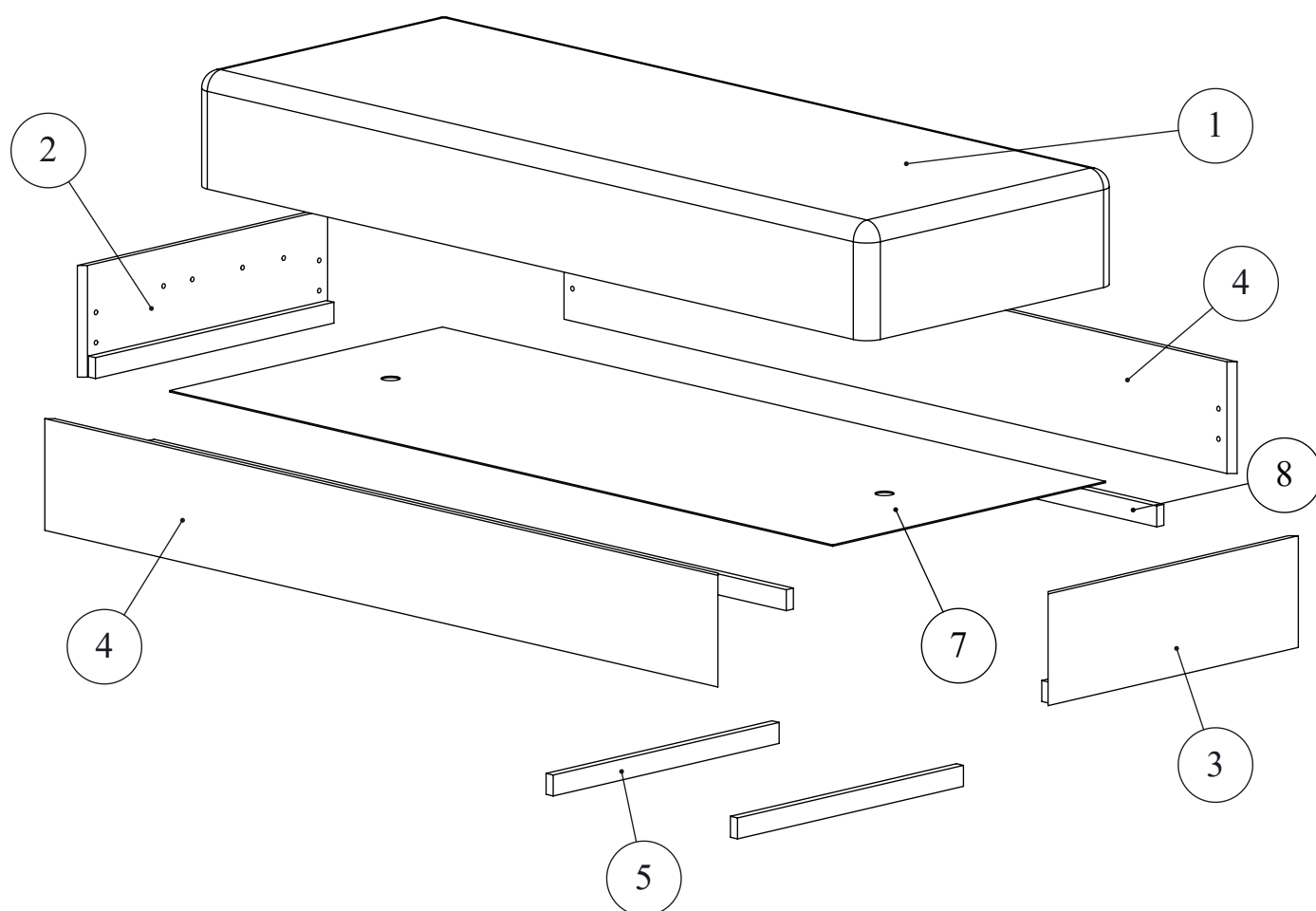

①	x2	⑦	x2
②	x2	⑧	x4
③	x2		
④	x4		
⑤	x4		

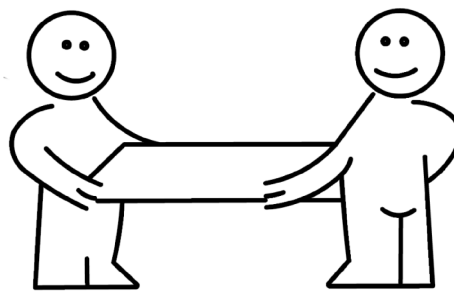
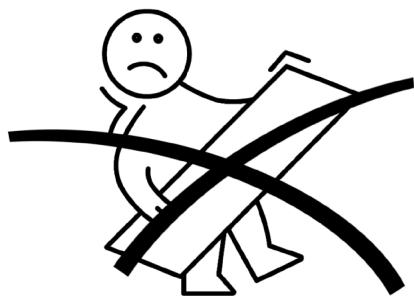

IMPORTANT - TWO PERSONS MINIMUM !!!

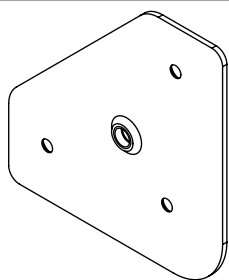

Ax4

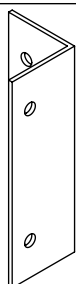

Bx4

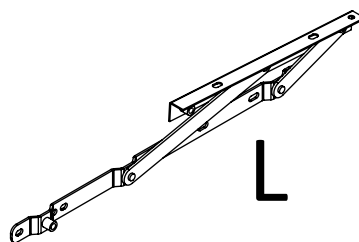

Cx1

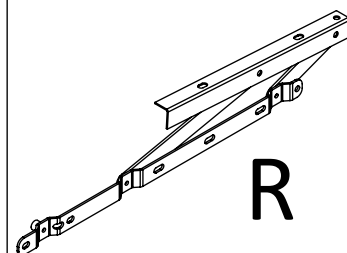

Dx1

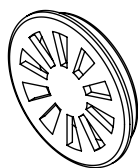

Ex2



Fx10

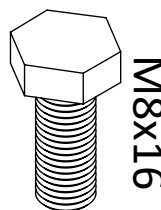

Gx4



Hx28



Ix4

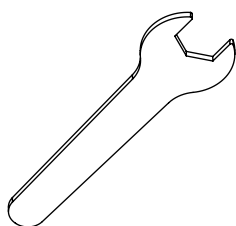

Jx1

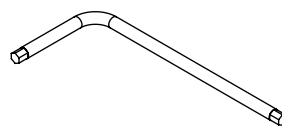

Kx1

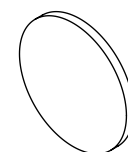

Lx4

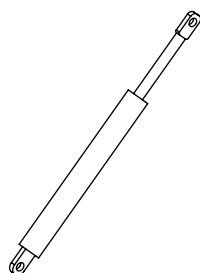

Mx2

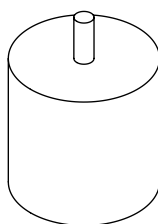

Nx4



Ox12

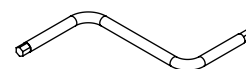

Px1

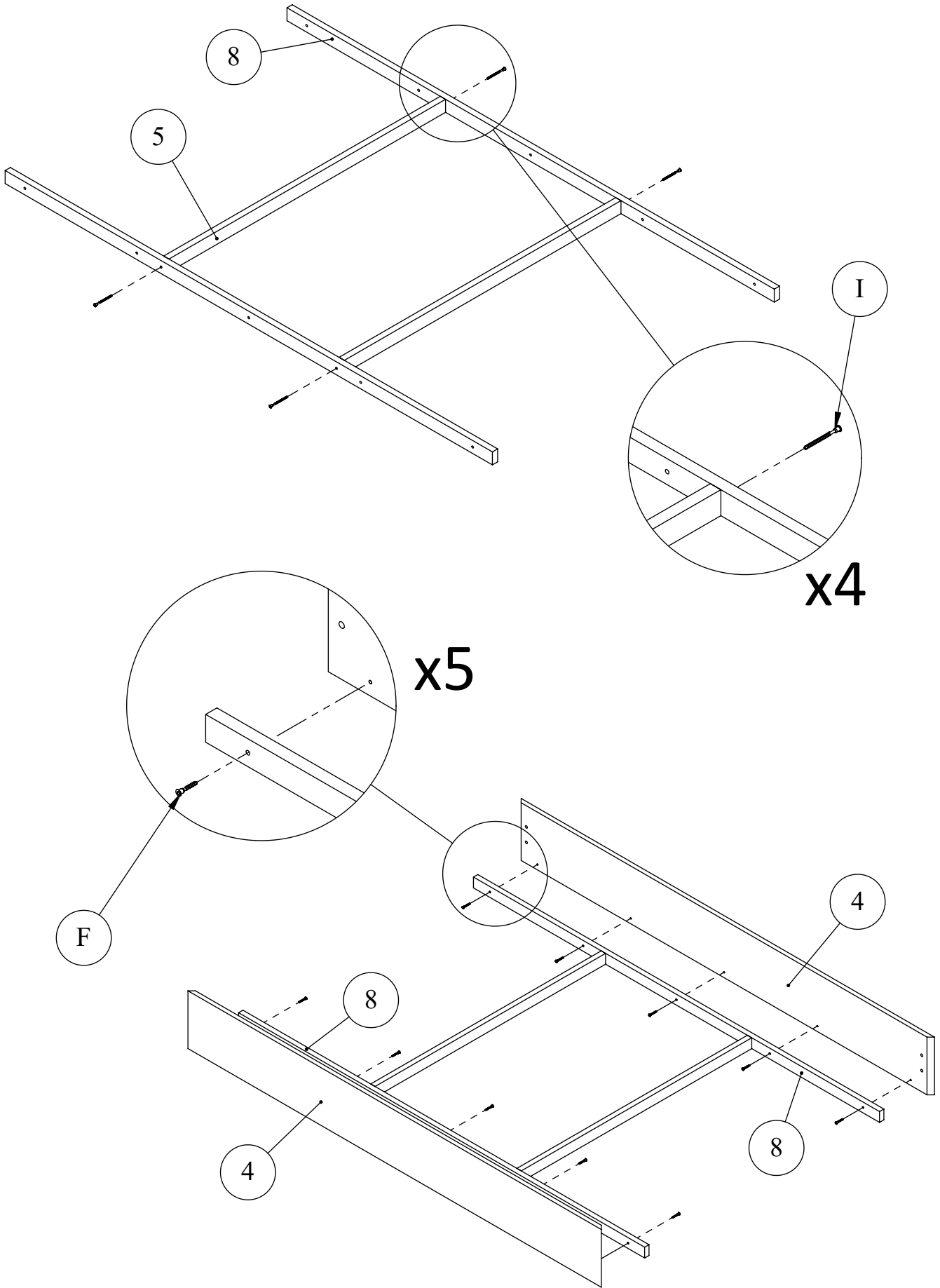

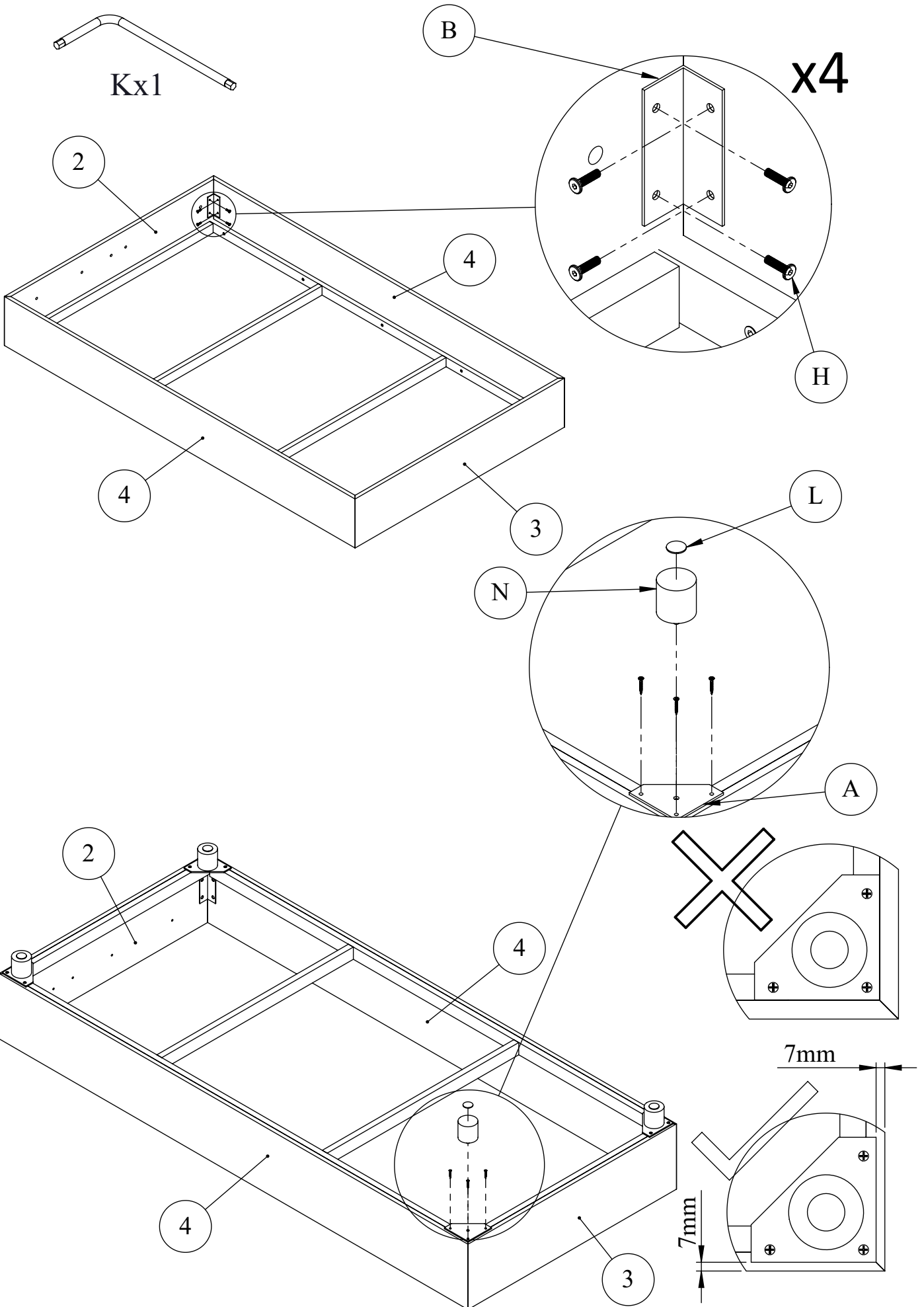

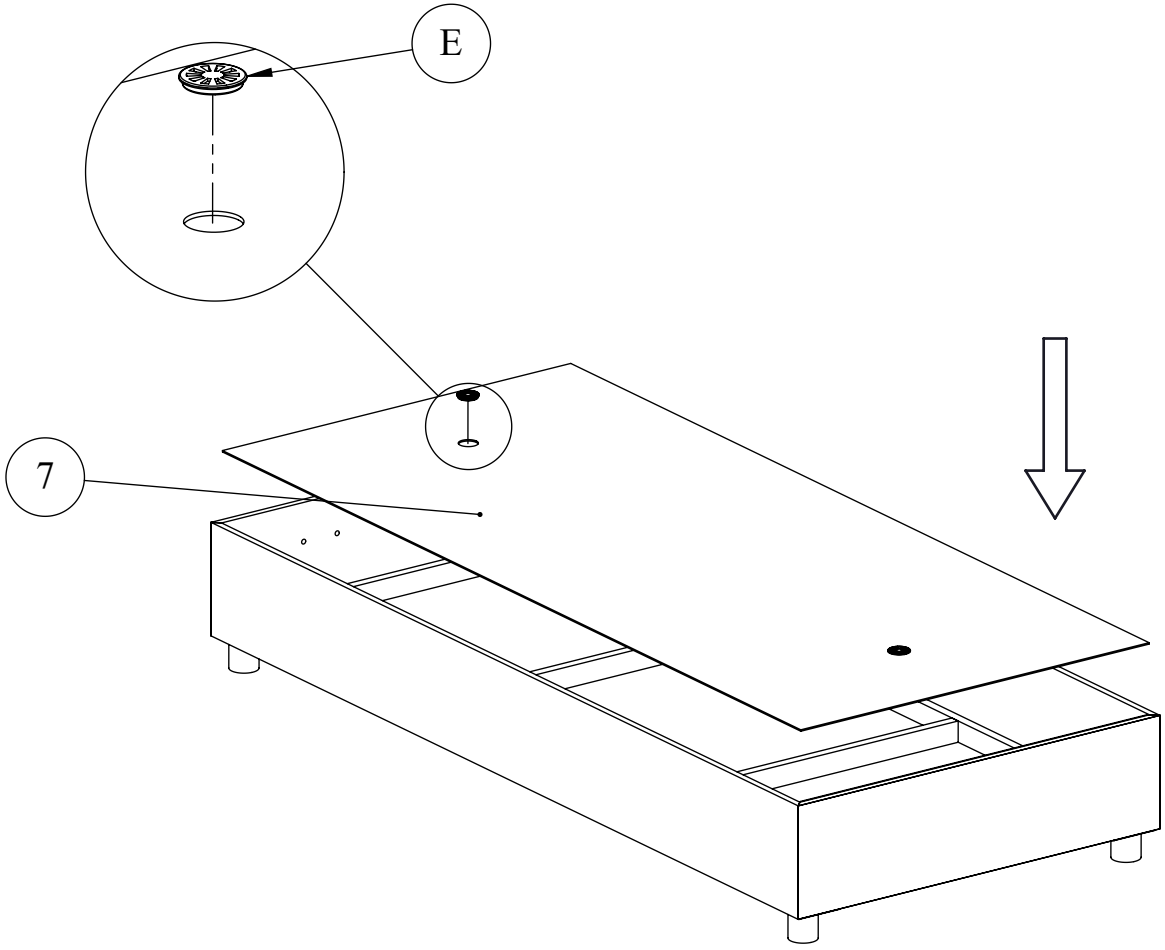

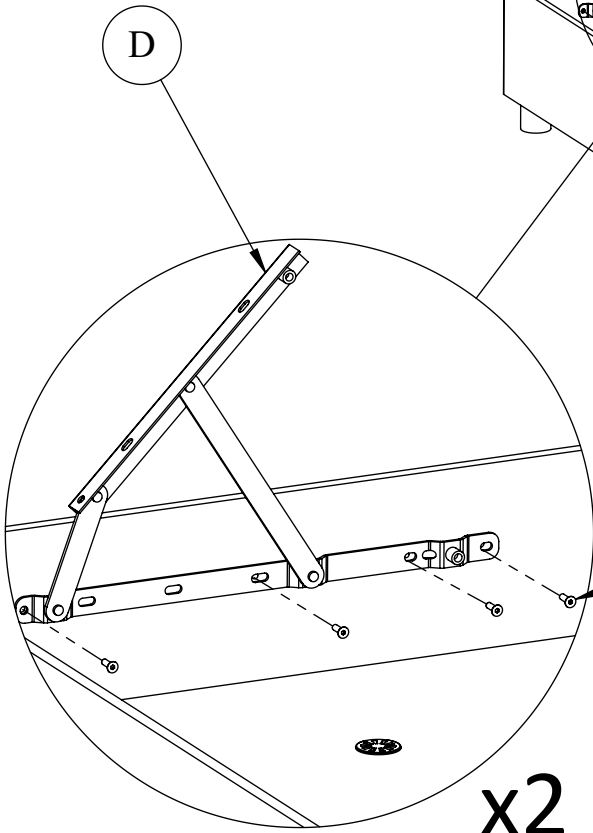
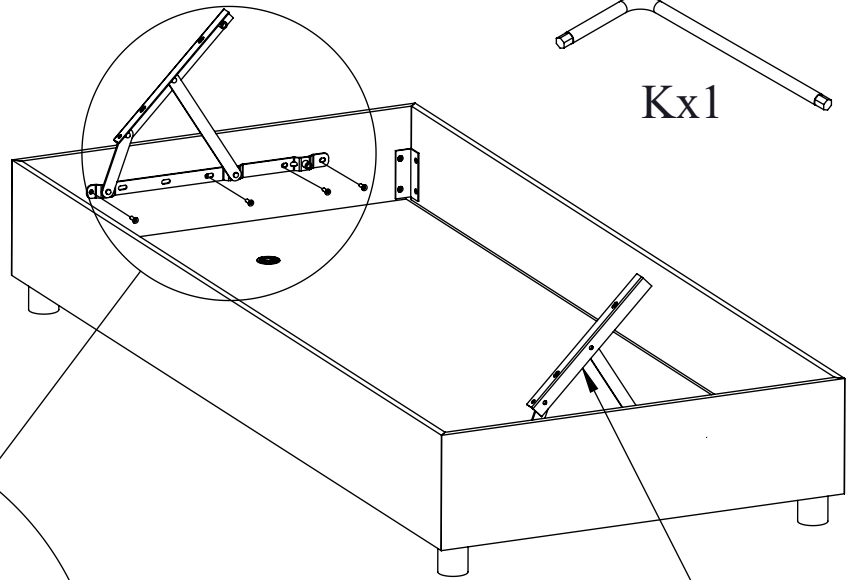
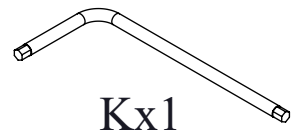

H

H screw all bolts 50%

x2

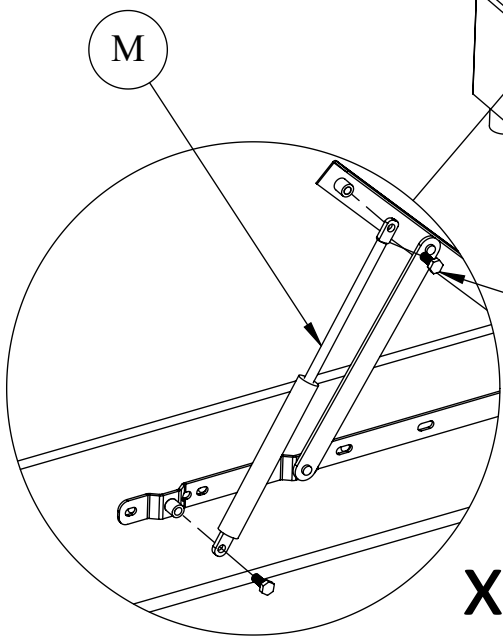
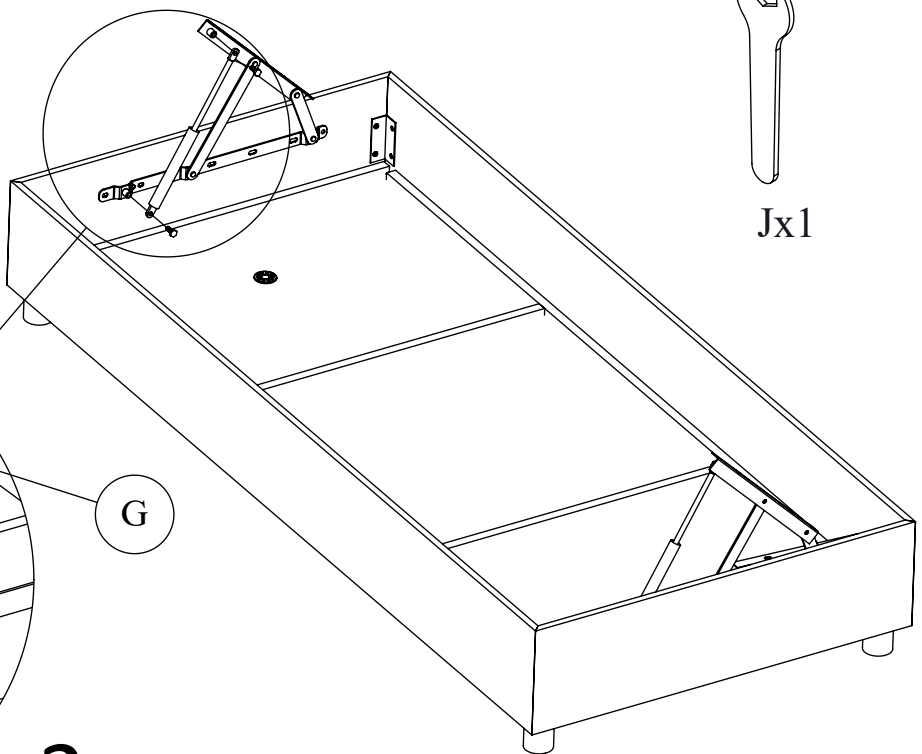
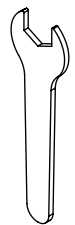

x2

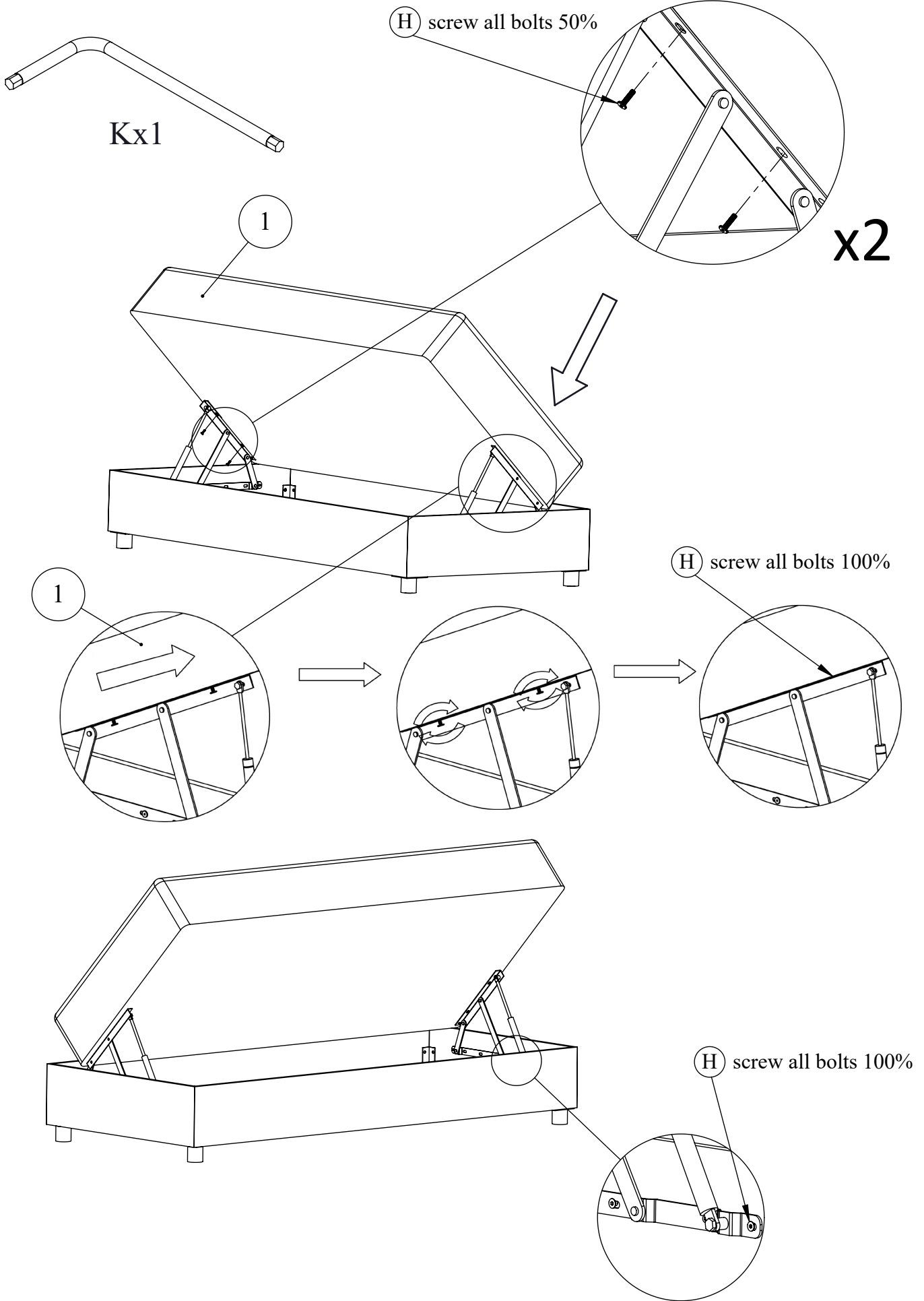

900 / 1200 / 1400 mm

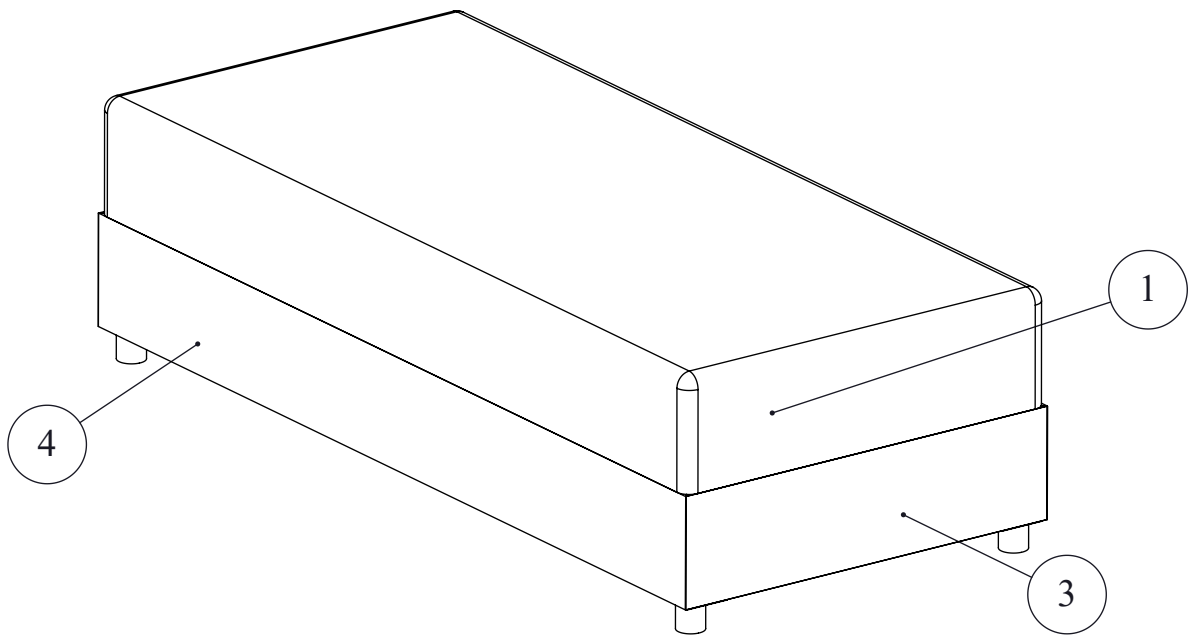

1600 / 1800 mm

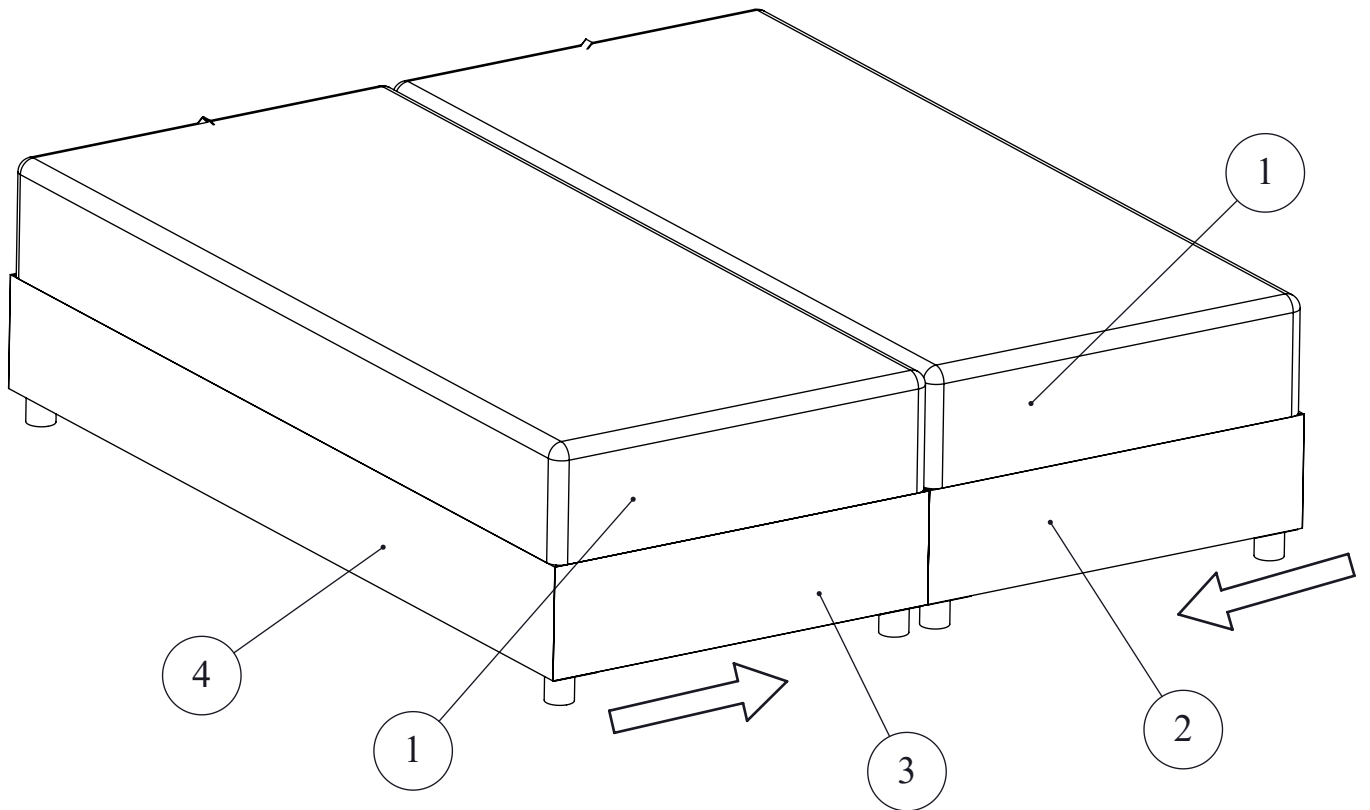

VEDLIGEHOVELSE AF SENGE

Sengen er typisk det møbel i hjemmet som bruges i flest timer gennem døgnet. Det betyder at sengen udsættes for et stort slid, og det er derfor vigtigt at man vedligeholder sin seng bedst muligt. Både levetiden, komforten og sundheden afhænger i høj grad af at man følger denne vejledning. For på den måde at sikre at man får mest mulig ud af sin seng.

OPSTILLING OG PLACERING

Når sengen opstilles, så bør man ikke stille sengen helt op af en ydervæg, da det kan give fugtproblemer. Skal sengen stå op af en væg, så bør man have nogle centimeter mellem væg og madras. Har sengen et midterben, så er det vigtigt at dette justeres så det støtter sengen midtpå under brug. Sengen udsættes for en stor mængde fugt fra kroppen i løbet af natten. Derfor bør man undgå at dække sengen til når den ikke bruges. Sengen skal helst kunne komme af med fugten og tørre i løbet af dagen, mens man ikke bruger sengen. Ligeledes bør man i vinterhalvåret sørge for at rummet er opvarmet for at sikre at sengen kan tørre og man undgår de problemer som fugt kan lede til. Ønsker man at sove for åbent vindue, så kan man med fordel åbne igen inden man går i seng.

VEDLIGEHOVELSE AF SENGE

De fleste af vores senge er med en vaskbar topmadras. Er topmadrassen vaskbar, så fremgår der en vaskeanvisning på den. Og på vaskbare topmadrasser, der er det generelt vigtigt at vaskeanvisning altid overholdes, herunder at man ikke bruger tørretumbler. Og at man når betrækket kommer ud af vaskemaskinen, strækker dette gentagne gange i begge retninger. Husk altid at indlægget i topmadrassen ikke tåler lys. Dette må derfor aldrig hænges udenfor mens man vasker betrækket. – Dette gælder i særdeleshed indlæg i latex. Selvom betrækket er vaskbart, så anbefaler vi at man bruger eksempelvis en rullemadras til at beskytte madrassen.

Alle vores senge og madrasser er vendbare på et eller flere leder. Det er vigtigt at man vender alle delene, herunder bundmadrasser, springmadrasser og topmadrasser hyppigt. Vi anbefaler at man gør dette en gang om måneden for at fordele sliddet på hele sengen bedst muligt. Vender man ikke madrasserne, så vil man primært få slid og sætning hvor man ligger med overkroppen. Ligeledes kan madrasser slides ud af facon på kanterne, særligt på dobbeltsenge hvis ikke madrasserne byttes rundt og slides jævnt. På fjedermadrasser kan man med fordel stille dem på siden, og banke dem let i forbindelse med man vender dem. Det vil ofte medvirke til at man får madrasserne til at bibeholde deres facon.

Der opstår sætning i alle vores senge under brug, og ligeledes vil man typisk opleve at komforten under brug kommer til at føles lidt blødere. Sætning i madrasser sker typisk mest i betrækket/quiltningen, dernæst i skummet og mindst i fjedrene. Som oftest vil dette gå hurtigst når sengen er helt ny, og der vil komme til at ske en højdereduktion der hvor sengen primært udsættes for kroppens tryk. En højdereduktion over tid på 5-10% er ikke unormalt. Konkret hvor meget afhænger af madraskonstruktionens højde, vedligeholdelse, materialer m.v.

Da madrasser er lavet af fleksible materialer, så er alle mål på madrasser ca. mål. Der vil altid være en tolerance på nogle procent.

MAINTENANCE OF BEDS / EN

The bed is typically the home furniture that is used for the most hours throughout the day. This means that the bed is exposed to a large amount of wear and it is therefore important that you maintain your bed as well as possible. Both the lifetime, comfort and health depend to a large extent on following this guide. This is to ensure that you make the most of your bed.

SET UP AND POSITIONING

When the bed is set up, do not place the bed right up next to an outer wall as it may cause moisture problems. If the bed needs to be placed next to a wall, you should at least have some centimeters between the wall and mattress. If the bed has a central leg underneath, it is important that this is adjusted to support the bed in the middle.

The bed is exposed to a large amount of moisture from the body during the night. Therefore, avoid covering the bed when not in use. The bed should preferably get rid of the moisture and dry during the day while you are not using the bed.

Likewise, during the winter season you should ensure that the room is heated to ensure that the bed can dry and avoids the problems that moisture can lead to. If you want to sleep with an open window, you may want to open again before going to bed.

MAINTENANCE OF BEDS / EN

Most of our beds comes with a washable top mattress. If the top mattress is washable, there is a washing instruction attached to it. On washable top mattresses, it is generally important that the washing instructions are always observed, including not using the tumble dryer, and when the cover comes out of the washing machine, it must repeatedly be stretched in both directions.

Always remember that the insert of the top mattress does not withstand light. This must therefore never be hanged outside while washing the cover. - This applies in particular to latex inserts. Even though the cover is washable, we recommend using a mattress pad to protect the mattress.

All our beds and mattresses are tunable in several ways. It is important to turn all the parts, including bottom mattresses, spring mattresses as well as top mattresses quite often.

We recommend doing this once a month to distribute the wear on the entire bed the best possible way. If you do not turn the mattresses, you will primarily get wear and tear where you lie with your upper body. Also, mattresses can be worn out on the edges, especially on double beds, if the mattresses are not turned and the wear spread evenly. On spring mattresses, you can, with advantage, put them on the side and tap them gently when turning them. It will often help to make the mattresses maintain their shape.

There is a saturation in all our beds during use, and you will typically find that the comfort during use will feel a bit softer as time goes. The saturation in mattresses typically takes place mostly in the cover / quilt, then in the foam and at the end also in the springs. Usually this will be fastest when the bed is brand new and there will be a reduction in height where the bed is primarily exposed to the body's pressure. A height reduction over time of 5-10% is not abnormal.

Exactly how much it reduces depends on the height of the mattress construction, maintenance, materials, etc.